

SIGHT DISTANCE GUIDELINES



**According to the 2011 AASHTO, 2011 MMUTCD, and
Michigan Department of Transportation Guidelines**

**PREPARED BY
GEOMETRICS AND OPERATIONS UNIT
TRAFFIC AND SAFETY
April 22, 2015**

"Providing the highest quality transportation services for economic benefit and improved quality of life."

INDEX

	PAGE NUMBER
ACKNOWLEDGEMENTS	iii
TYPES OF SIGHT DISTANCE	iii
STOPPING SIGHT DISTANCE	1
Quick Charts for Stopping Sight Distance	3
STOPPING SIGHT DISTANCE	5
Horizontal Stopping Sight Distance.....	6
Vertical Curves	10
Crest Vertical Curves	11
Sag Vertical Curves.....	13
Design Controls: Stopping Sight Distance	16
General Control for Vertical Alignment	18
PASSING SIGHT DISTANCE	19
Quick Charts for Passing Sight Distance	21
PASSING SIGHT DISTANCE (Two-Lane, Two-Way Highways)	23
Measurement of Passing Sight Distance.....	24
Passing Sight Distance on Multilane Roadways.....	25
Passing Sight Distance for Horizontal Curves.....	25
Passing Sight Distance for Vertical Curves	26
Passing Sight Distance - Pavement Markings	27
DECISION SIGHT DISTANCE	30
Quick Chart for Decision Sight Distance	31
DECISION SIGHT DISTANCE	33
INTERSECTION SIGHT DISTANCE	37
Quick Charts for Intersection Sight Distance	39
INTERSECTION SIGHT DISTANCE	41
Intersections with Stop-Control on the Minor Road.....	42
Intersection Sight Distance Considerations for Signalized Intersections.....	48
Determination and Measurement of Intersection Sight Distance.....	48
Field Measurement of Intersection Sight Distance.....	51
REFERENCES	52

ACKNOWLEDGEMENTS

The Michigan Department of Transportation (MDOT) practices regarding sight distance measurement are based almost exclusively and entirely upon the AASHTO sight distance principles, theories, and methodologies. Therefore, it was not possible to produce this reference document without utilizing significant portions of the *A Policy on Geometric Design of Highways and Streets*, 2011, by the American Association of State Highway and Traffic Officials (AASHTO), Washington, D.C. MDOT would like to acknowledge the AASHTO publication (used by permission) as the major source material within this document. As a result, several sections of the AASHTO publication were incorporated into this document, either directly and intact, or paraphrased for ease of explanation and/or understanding. Acknowledgements are also extended to the *Michigan Manual on Uniform Traffic Control Devices* (MMUTCD), 2011 Edition, for additional source material.

In general, the information in this document can be found in Chapters 3 and 9 of the AASHTO publication, and in Part 3 of the MMUTCD publication. For all references used in this guide, the document and page number is provided, i.e. (2011 AASHTO, 3-1).

TYPES OF SIGHT DISTANCE

“Sight distance is the distance along a roadway throughout which an object of specified height is continuously visible to the driver. This distance is dependent on the height of the driver’s eye above the road surface, the specified object height above the road surface, and the height and lateral position of sight obstructions within the driver’s line of sight.” (2011 AASHTO, 3-14)

Following are the four types of sight distance:

- Stopping Sight Distance
- Passing Sight Distance
- Decision Sight Distance
- Intersection Sight Distance

Each of the different types of sight distance will be further detailed in the next four sections.

STOPPING SIGHT DISTANCE

Quick Charts for Stopping Sight Distance

Design Speed (mph)	Stopping Sight Distance (ft)	Rate of Vertical Curvature, K*	
		Calculated	Design
15	80	3.0	3
20	115	6.1	7
25	155	11.1	12
30	200	18.5	19
35	250	29.0	29
40	305	43.1	44
45	360	60.1	61
50	425	83.7	84
55	495	113.5	114
60	570	150.6	151
65	645	192.8	193
70	730	246.9	247
75	820	311.6	312
80	910	383.7	384

Design Controls for Stopping Sight Distance and Crest Vertical Curves (2011 AASHTO, Exhibit 3-34, 3-155)

Design Speed (mph)	Stopping Sight Distance (ft)	Rate of Vertical Curvature, K*	
		Calculated	Design
15	80	9.4	10
20	115	16.5	17
25	155	25.5	26
30	200	36.4	37
35	250	49.0	49
40	305	63.4	64
45	360	78.1	79
50	425	95.7	96
55	495	114.9	115
60	570	135.7	136
65	645	156.5	157
70	730	180.3	181
75	820	205.6	206
80	910	231.0	231

Design Controls for Stopping Sight Distance and Sag Vertical Curves (2011, AASHTO, Exhibit 3-36, 3-161)

*Rate of vertical curvature, K, is the length of curve (L) per percent Algebraic difference on intersecting grades (A). $K = L/A$

STOPPING SIGHT DISTANCE

“Stopping sight distance is the minimum sight distance required along a roadway to enable a vehicle traveling at or near the design speed to stop before reaching a stationary object in its path.

Stopping sight distance is the sum of two distances: (1) the distance traversed by the vehicle from the instant the driver sights an object necessitating a stop to the instant the brakes are applied (Brake Reaction Distance); and (2) the distance needed to stop the vehicle from the instant brake application begins (Braking Distance).” (2011 AASHTO, 3-2)

Brake Reaction Distance = $1.47Vt$ (2011 AASHTO, Equation 3-2, 3-3)

Where:

V = design speed (mph)

t = brake reaction time (2.5 sec assumed)

Braking Distance = $1.075 V^2 / a$ (2011 AASHTO, Equation 3-1, 3-3)

Where:

V = design speed (mph)

a = deceleration rate (11.2 ft/s² assumed)

Therefore:

Stopping Sight Distance = $1.47Vt + 1.075V^2 / a$ (2011 AASHTO, Equation 3-2, 3-4)

Or simplified:

SSD = $3.675V + 0.096V^2$

When the highway is on a grade the braking distance is increased and the equation is modified as follows:*

Braking Distance = $V^2 / [30((a / 32.2) \pm G / 100)]$ (2011 AASHTO, Equation 3-3, 3-5)

Where:

V = design speed (mph)

a = deceleration rate (11.2 ft/s² assumed)

G = percent grade

*As a general rule, MDOT does not typically adjust stopping sight distance due to grade. While a downward grade requires additional distance to stop, this is mitigated by the fact that the driver has a higher effective eye height. Conversely, while effective driver eye height may be lower on an upward grade, the distance that is required to stop is lessened due to the effect of gravity. (2011 AASHTO, 3-6)

Design Speed (mph)	Brake Reaction Distance (ft)	Braking Distance on Level (ft)	Stopping Sight Distance	
			Calculated (ft)	Design (ft)
15	55.1	21.6	76.7	80
20	73.5	38.4	111.9	115
25	91.9	60.0	151.9	155
30	110.3	86.4	196.7	200
35	128.6	117.6	246.2	250
40	147.0	153.6	300.6	305
45	165.4	194.4	359.8	360
50	183.8	240.0	423.8	425
55	202.1	290.3	492.4	495
60	220.5	345.5	566.0	570
65	238.9	405.5	644.4	645
70	257.3	470.3	727.6	730
75	275.6	539.9	815.5	820
80	294.0	614.3	908.3	910

Exhibit 1 Stopping Sight Distance (2011 AASHTO Table 3-1, 3-4)

Horizontal Stopping Sight Distance

“Another element of horizontal alignment is the sight distance across the inside of curves (often referred to as Horizontal Sightline Offset. Horizontal Sightline Offset (HSO) is the minimum distance required between the roadside and an obstruction, measured from the centerline of the inside lane to the face of the obstruction.)

Where there are sight obstructions (such as retaining walls, cut slopes, concrete barriers, buildings, and longitudinal barriers) on the inside of curves or the inside of the median lane on divided highways and their removal to increase sight distance is impractical, a design may need adjustment in the normal highway cross section or the alignment. Because of the many variables in alignment, in cross section, and in the number, type and location of the potential obstructions, specific study is usually needed for each individual curve. With sight distance for the design speed as a control, the designer should check the actual conditions on each curve and make the appropriate adjustments to provide adequate sight distance.

For general use in design of a horizontal curve, the sight line is a chord of the curve, and the (horizontal) stopping sight distance is measured along the centerline of the inside lane around the curve (See Figure 3-23)” (2011 AASHTO, 3-106)

The following equation applies only to circular curves longer than the sight distance for the pertinent design speed:

$$HSO = R [1 - \cos ((28.65S) / R)] \quad (2011 AASHTO, Equation 3-36, 3-109)$$

Where: S = Stopping Sight Distance (ft)

R = Radius of Curve (ft)

HSO = Horizontal Sightline Offset

The results of this equation are tabulated in the following table:

Table 1 Horizontal Sight Distance- Horizontal Sightline Offset (HSO)* (ft)

Design Speed (mph)

Radius** (ft)	25	30	35	40	45	50	55	60	65	70	75
200	14.8	24.5	37.8	55.4	75.7	102.7	134.6	171.0	208.4	250.3	292.2
250	11.9	19.7	30.6	45.1	62.1	85.0	112.8	145.6	180.7	222.4	267.3
300	10.0	16.5	25.7	37.9	52.4	72.2	96.4	125.5	157.3	196.0	239.2
350	8.5	14.2	22.1	32.7	45.3	62.6	83.9	109.8	138.4	173.7	213.9
400	7.5	12.4	19.4	28.7	39.8	55.1	74.2	97.3	123.1	155.3	192.4
450	6.7	11.1	17.3	25.6	35.5	49.3	66.4	87.3	110.7	140.1	174.2
500	6.0	10.0	15.5	23.1	32.1	44.5	60.0	79.1	100.5	127.4	158.9
550	5.5	9.1	14.1	21.0	29.2	40.5	54.8	72.2	91.9	116.7	145.9
600	5.0	8.3	13.0	19.3	26.8	37.2	50.3	66.4	84.6	107.7	134.7
650	4.6	7.7	12.0	17.8	24.8	34.4	46.6	61.5	78.4	99.8	125.1
700	4.3	7.1	11.1	16.5	23.0	32.0	43.3	57.2	73.0	93.0	116.7
750	4.0	6.7	10.4	15.5	21.5	29.9	40.5	53.5	68.3	87.1	109.3
800	3.8	6.2	9.7	14.5	20.2	28.1	38.0	50.2	64.1	81.8	102.8
850	3.5	5.9	9.2	13.6	19.0	26.4	35.8	47.3	60.5	77.2	97.0
900	3.3	5.6	8.7	12.9	17.9	25.0	33.8	44.8	57.2	73.0	91.8
950	3.2	5.3	8.2	12.2	17.0	23.7	32.1	42.4	54.2	69.3	87.1
1000	3.0	5.0	7.8	11.6	16.2	22.5	30.5	40.3	51.6	65.9	82.9
1050	2.9	4.8	7.4	11.1	15.4	21.4	29.0	38.4	49.1	62.8	79.0
1100	2.7	4.5	7.1	10.6	14.7	20.5	27.7	36.7	46.9	60.0	75.5
1150	2.6	4.3	6.8	10.1	14.1	19.6	26.5	35.1	44.9	57.4	72.3
1200	2.5	4.2	6.5	9.7	13.5	18.8	25.4	33.7	43.1	55.1	69.4
1250	2.4	4.0	6.2	9.3	12.9	18.0	24.4	32.4	41.4	52.9	66.6
1300	2.3	3.8	6.0	8.9	12.4	17.3	23.5	31.1	39.8	50.9	64.1
1350	2.2	3.7	5.8	8.6	12.0	16.7	22.6	30.0	38.3	49.0	61.8
1400	2.1	3.6	5.6	8.3	11.6	16.1	21.8	28.9	37.0	47.3	59.6
1450	2.1	3.4	5.4	8.0	11.2	15.5	21.1	27.9	35.7	45.7	57.6
1500	2.0	3.3	5.2	7.7	10.8	15.0	20.4	27.0	34.5	44.2	55.7
1550	1.9	3.2	5.0	7.5	10.4	14.5	19.7	26.1	33.4	42.8	53.9
1600	1.9	3.1	4.9	7.3	10.1	14.1	19.1	25.3	32.4	41.5	52.3
1650	1.8	3.0	4.7	7.0	9.8	13.7	18.5	24.6	31.4	40.2	50.7
1700	1.8	2.9	4.6	6.8	9.5	13.3	18.0	23.8	30.5	39.0	49.2
1750	1.7	2.9	4.5	6.6	9.3	12.9	17.5	23.2	29.6	37.9	47.8
1800	1.7	2.8	4.3	6.5	9.0	12.5	17.0	22.5	28.8	36.9	46.5
1850	1.6	2.7	4.2	6.3	8.8	12.2	16.5	21.9	28.0	35.9	45.3
1900	1.6	2.6	4.1	6.1	8.5	11.9	16.1	21.3	27.3	35.0	44.1
1950	1.5	2.6	4.0	6.0	8.3	11.6	15.7	20.8	26.6	34.1	43.0
2000	1.5	2.5	3.9	5.8	8.1	11.3	15.3	20.3	25.9	33.2	41.9

* This table provides the horizontal sightline offset distance. The offset that is provided is measured from the centerline of the inside lane to the face of the obstruction.

** The horizontal curve radius should be measured for the centerline of the inside lane.

Note: The results of the equation apply only to circular curves longer than the sight distance for the pertinent design speed.

Table 1 Horizontal Sight Distance- Horizontal Sightline Offset (HSO)* (ft) (con't.)											
Design Speed (mph)											
Radius** (ft)	25	30	35	40	45	50	55	60	65	70	75
2050	1.5	2.4	3.8	5.7	7.9	11.0	14.9	19.8	25.3	32.4	40.9
2100	1.4	2.4	3.7	5.5	7.7	10.7	14.6	19.3	24.7	31.6	39.9
2150	1.4	2.3	3.6	5.4	7.5	10.5	14.2	18.9	24.1	30.9	39.0
2200	1.4	2.3	3.6	5.3	7.4	10.3	13.9	18.4	23.6	30.2	38.1
2250	1.3	2.2	3.5	5.2	7.2	10.0	13.6	18.0	23.1	29.5	37.3
2300	1.3	2.2	3.4	5.1	7.0	9.8	13.3	17.6	22.6	28.9	36.5
2350	1.3	2.1	3.3	4.9	6.9	9.6	13.0	17.3	22.1	28.3	35.7
2400	1.3	2.1	3.3	4.8	6.7	9.4	12.8	16.9	21.6	27.7	34.9
2450	1.2	2.0	3.2	4.7	6.6	9.2	12.5	16.6	21.2	27.1	34.2
2500	1.2	2.0	3.1	4.7	6.5	9.0	12.2	16.2	20.8	26.6	33.5
2550	1.2	2.0	3.1	4.6	6.4	8.9	12.0	15.9	20.4	26.1	32.9
2600	1.2	1.9	3.0	4.5	6.2	8.7	11.8	15.6	20.0	25.6	32.3
2650	1.1	1.9	2.9	4.4	6.1	8.5	11.6	15.3	19.6	25.1	31.7
2700	1.1	1.9	2.9	4.3	6.0	8.4	11.3	15.0	19.2	24.6	31.1
2750	1.1	1.8	2.8	4.2	5.9	8.2	11.1	14.8	18.9	24.2	30.5
2800	1.1	1.8	2.8	4.2	5.8	8.1	10.9	14.5	18.6	23.8	30.0
2850	1.1	1.8	2.7	4.1	5.7	7.9	10.7	14.2	18.2	23.3	29.4
2900	1.0	1.7	2.7	4.0	5.6	7.8	10.6	14.0	17.9	22.9	28.9
2950	1.0	1.7	2.6	3.9	5.5	7.7	10.4	13.8	17.6	22.6	28.4
3000	1.0	1.7	2.6	3.9	5.4	7.5	10.2	13.5	17.3	22.2	28.0
3050	1.0	1.6	2.6	3.8	5.3	7.4	10.0	13.3	17.0	21.8	27.5
3100	1.0	1.6	2.5	3.8	5.2	7.3	9.9	13.1	16.8	21.5	27.1
3150	1.0	1.6	2.5	3.7	5.1	7.2	9.7	12.9	16.5	21.1	26.6
3200	0.9	1.6	2.4	3.6	5.1	7.1	9.6	12.7	16.2	20.8	26.2
3250	0.9	1.5	2.4	3.6	5.0	6.9	9.4	12.5	16.0	20.5	25.8
3300	0.9	1.5	2.4	3.5	4.9	6.8	9.3	12.3	15.7	20.2	25.4
3350	0.9	1.5	2.3	3.5	4.8	6.7	9.1	12.1	15.5	19.9	25.1
3400	0.9	1.5	2.3	3.4	4.8	6.6	9.0	11.9	15.3	19.6	24.7
3450	0.9	1.4	2.3	3.4	4.7	6.5	8.9	11.8	15.1	19.3	24.3
3500	0.9	1.4	2.2	3.3	4.6	6.4	8.7	11.6	14.8	19.0	24.0
3550	0.8	1.4	2.2	3.3	4.6	6.4	8.6	11.4	14.6	18.8	23.7
3600	0.8	1.4	2.2	3.2	4.5	6.3	8.5	11.3	14.4	18.5	23.3
3650	0.8	1.4	2.1	3.2	4.4	6.2	8.4	11.1	14.2	18.2	23.0
3700	0.8	1.4	2.1	3.1	4.4	6.1	8.3	11.0	14.0	18.0	22.7
3750	0.8	1.3	2.1	3.1	4.3	6.0	8.2	10.8	13.9	17.8	22.4
3800	0.8	1.3	2.1	3.1	4.3	5.9	8.1	10.7	13.7	17.5	22.1
3850	0.8	1.3	2.0	3.0	4.2	5.9	8.0	10.5	13.5	17.3	21.8

* This table provides the horizontal sightline offset distance. The offset that is provided is measured from the centerline of the inside lane to the face of the obstruction.

** The horizontal curve radius should be measured for the centerline of the inside lane.

Note: The results of the equation apply only to circular curves longer than the sight distance for the pertinent design speed.

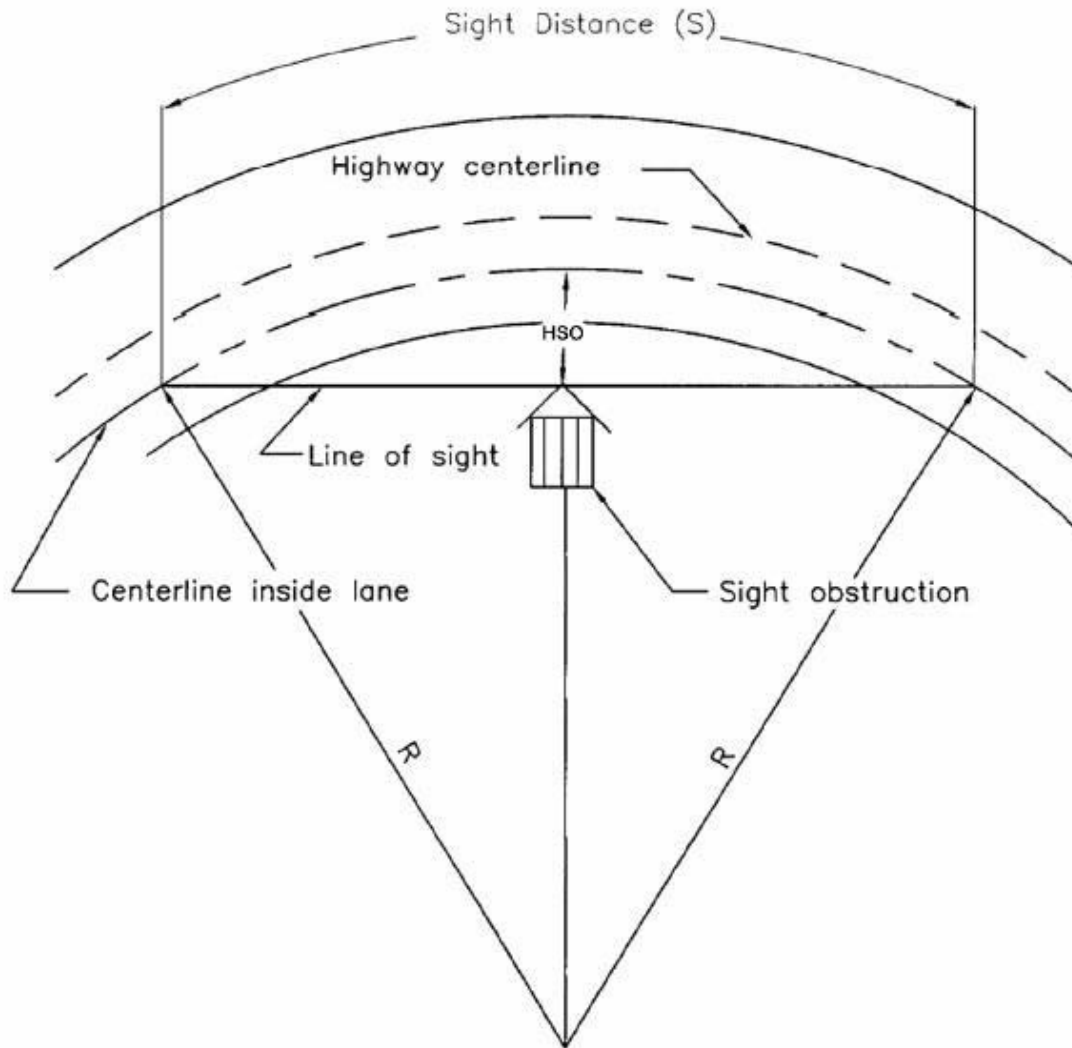

Exhibit 2 Diagram Illustrating Components for Determining Horizontal Sight Distance (2011 AASHTO Exhibit 3-23, 3-109)

“Horizontal sight restrictions may occur where there is a cut slope (or other obstruction) on the inside of the curve. For the 1.08 m (3.5 feet) eye height and the 0.60 m (2.0 feet) object height used for stopping sight distance, a height of 0.84 m (2.75 feet) may be used as the midpoint of the sight line where the cut slope usually obstructs sight. This assumes that there is little or no vertical curvature.” (2011 AASHTO, 3-109)

“Where sufficient stopping sight distance is not available because a railing or a longitudinal barrier constitutes a sight obstruction, alternative designs should be considered. The alternatives are: (1) increase the offset to the obstruction, (2) increase the horizontal curve radius, or (3) reduce the design speed. However, the alternative selected should not incorporate shoulder widths on the inside of the curve in excess of 3.6 m (12 feet) because of the concern that drivers will use wider shoulders as a passing or travel lane.” (2011 AASHTO, 3-110)

Vertical Curves

General Considerations

“Vertical curves to effect gradual changes between tangent grades may be any one of the crest or sag types depicted in Figure 3-41. Vertical curves should be simple in application and should result in a design that enables the driver to see the road ahead, enhances vehicle control, is pleasing in appearance, and adequate for drainage. The major control for safe operation on crest vertical curves is the provision for ample sight distances for the design speed; while research has shown the vertical curves with limited sight distance do not necessarily experience safety problems, it is recommended that all vertical curves be designed to provide at least the stopping sight distances shown in Table 3-1. Wherever practical, more liberal stopping sight distances should be used. Furthermore, additional sight distance should be provided at decision points.” (2011 AASHTO, 3-149)

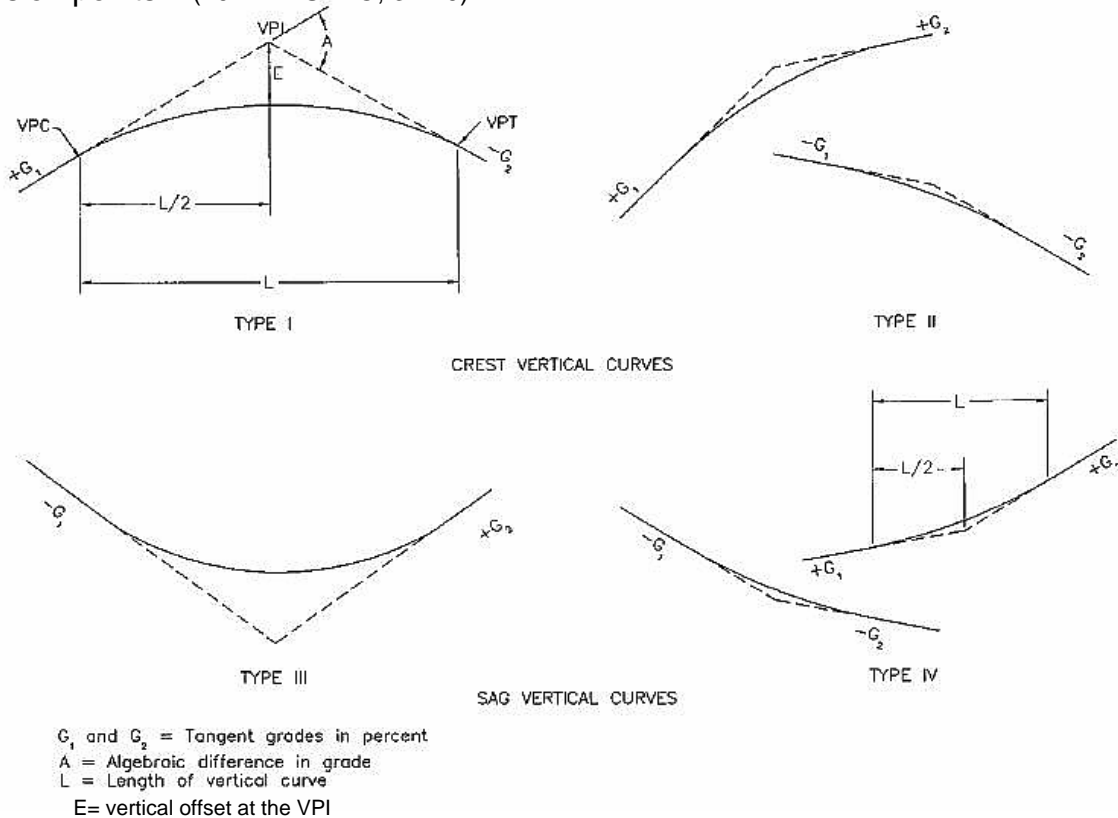

Exhibit 3 Types of Vertical Curves (2011 AASHTO, Figure 3-41, 3-150)

“For driver comfort, the rate of change of grade should be kept within tolerable limits. This consideration is most important in sag vertical curves where gravitational and vertical centripetal forces act in opposite directions. Appearance also should be considered in designing vertical curves. A long curve has a more pleasing appearance than a short one; short vertical curves may give the appearance of a sudden break in the profile due to the effect of foreshortening.

Drainage of curbed roadways on sag vertical curves (Type III in Figure 3-41) needs careful profile design to retain a grade of not less than 0.5 percent or, in some cases, 0.30 percent for the outer edges of the roadway. While not desirable, flatter grades may be appropriate in some situations.” (2011 AASHTO, 3-150)

“The rate of change of grade at successive points on the curve is a constant amount for equal increments of horizontal distance, and is equal to the algebraic difference between intersecting tangent grades divided by the length of curve in meters (feet), or A/L in percent per meter (percent per foot). The reciprocal L/A is the horizontal distance in meters (feet) needed to make a 1 percent change in gradient and is, therefore, a measure of curvature. The quantity L/A , termed “K”, is useful in determining the horizontal distance from the Point of Vertical Curvature (VPC) to the high point of Type 1 curves or to the low point of Type III curves. This point where the slope is zero occurs at a distance from the VPC equal to K times the approach gradient. The value of K is also useful in determining minimum lengths of vertical curves for various design speeds.

The selection of design curves is facilitated because the minimum length of curve in meters (feet) is equal to K times the algebraic difference in percent, $L=KA$. Conversely, the checking of plans is simplified by comparing all curves with the design value for K.” (2011 AASHTO,3-150,151,153)

Crest Vertical Curves

“Minimum lengths of crest vertical curves based on sight distance criteria are satisfactory from the standpoint of safety, comfort, and appearance. An exception may be at decision areas, such as ramp exit gores, where longer sight distances and, therefore, longer vertical curves should be provided; for further information, refer to Section 3.2.3, “Decision Sight Distance.”

Figure 3-42 illustrates the parameters used in determining the length of a parabolic crest vertical curve needed to provide any specified value of sight distance.” (2011 AASHTO, 3-151)

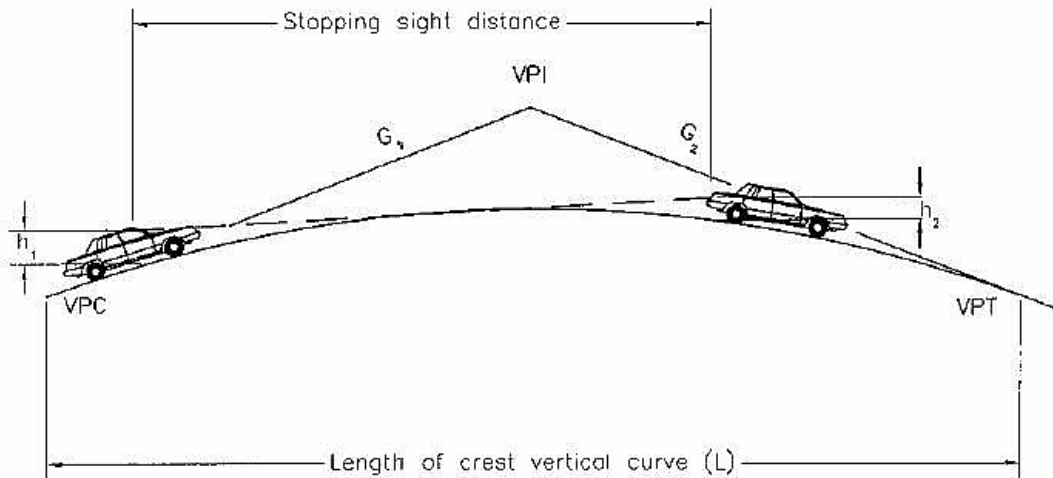

Exhibit 4 Parameters Considered in Determining the Length of a Crest Vertical Curve to Provide Sight Distance (2011 AASHTO, Figure 3-42, 3-152)

When S is less than L:

$$L = (AS^2) / (100 (\sqrt{(2h_1)} + \sqrt{(2h_2)})^2)$$

(2011 AASHTO, Equation 3-41, 3-151)

When S is greater than L:

$$L = 2S - ((200(\sqrt{(h_1)} + \sqrt{(h_2)})^2) / A)$$

(2011 AASHTO, Equation 3-42, 3-151)

Where:

L = length of vertical curve (ft)

S = sight distance (ft)

A = algebraic difference in grades (percent)

h_1 = height of eye above roadway surface (ft)

h_2 = height of object above roadway surface (ft)

“When the height of eye and the height of object are 3.5 feet and 2.0 feet respectively, as used for stopping sight distance, the equations become:” (2011 AASHTO, 3-152)

When S is less than

$$L: L = (AS^2) / 2158$$

(2011 AASHTO, Equation 3-43, 3-152)

When S is greater than

$$L: L = 2S - (2158 / A)$$

(2011 AASHTO, Equation 3-44, 3-152)

Where:

L = length of vertical curve (ft)

S = sight distance (ft)

A = algebraic difference in grades (percent)

h_1 = height of eye above roadway surface (ft)

h_2 = height of object above roadway surface (ft)

Design Speed (mph)	Stopping Sight Distance (ft)	Rate of Vertical Curvature, K*	
		Calculated	Design
15	80	3.0	3
20	115	6.1	7
25	155	11.1	12
30	200	18.5	19
35	250	29.0	29
40	305	43.1	44
45	360	60.1	61
50	425	83.7	84
55	495	113.5	114
60	570	150.6	151
65	645	192.8	193
70	730	246.9	247
75	820	311.6	312
80	910	383.7	384

Exhibit 5 Design Controls for Crest Vertical Curves

(2011 AASHTO, Table 3-34, 3-155)

*Rate of vertical curvature, K, is the length of curve (L) per percent algebraic difference on intersecting grades (A). $K = L/A$

Sag Vertical Curves

“At least four different criteria for establishing lengths of sag vertical curves are recognized to some extent. These are (1) headlight sight distance, (2) passenger comfort, (3) drainage control, and (4) general appearance.” (2011 AASHTO, 3-157)

Headlight illumination distance has, for the most part, been used by MDOT as the basis for determining the lengths of sag vertical curves as recommended here. “When a vehicle traverses a sag vertical curve at night, the portion of highway lighted ahead is dependent on the position of the headlights and the direction of the light beam. A headlight height of 2 feet and a 1-degree upward divergence of the light beam from the longitudinal axis of the vehicle are commonly assumed. The upward spread of the light beam above the 1-degree divergence angle provides some additional visible length of roadway, but is not generally considered in design.

The following equations show the relationships between S, L and A, using S as the sight distance between the vehicle and point where the 1-degree upward angle of the light beam intersects the surface of the roadway:" (2011 AASHTO, 3-158)

When S is less than L: (2011 AASHTO, Equation 3-48, 3-158)
$$L = (AS^2) / (400 + 3.5S)$$

When S is greater than L: (2011 AASHTO, Equation 3-50, 3-158)
$$L = 2S - ((400 + 3.5S) / A)$$

Where:

- L = length of sag vertical curve (ft)
- S = light beam distance (ft) (assume stopping sight distance for proper design speed)
- A = algebraic difference in grades (percent)

"For overall safety on highways, a sag vertical curve should be long enough so that the light beam distance is nearly the same as the stopping sight distance. Accordingly, it is appropriate to use the stopping sight distances for different design speeds as the value of S in the above equations.

The effect on passenger comfort of the change in vertical direction is greater on sag than on crest vertical curves because gravitational and centripetal forces are in opposite directions, rather than in the same direction. Comfort due to change in vertical direction is not readily measured because it is affected appreciably by vehicle body suspension, vehicle body weight, tire flexibility, and other factors. Limited attempts at such measurements have led to the broad conclusion that riding is comfortable on sag vertical curves when the centripetal acceleration does not exceed 1 ft/s². The general expression for such a criterion is:" (2011 AASHTO, 3-160)

$$L = (AV^2) / 46.5 \quad (2011 AASHTO, Equation 3-51, 3-160)$$

Where:

- L = length of sag vertical curve (ft)
- A = algebraic difference in grades (percent)
- V = design speed (mph)

"The length of vertical curve needed to satisfy this comfort factor at the various design speeds is only about 50 percent of that needed to satisfy the headlight sight distance criterion for the normal range of design conditions.

Drainage affects design of the vertical curves of Type III (see Exhibit 3) where curbed sections are used. An approximate criterion for sag vertical curves is the same as that expressed for the crest conditions (i.e., a minimum grade of 0.30 percent should be provided within 50 feet of the level point). This criterion corresponds to K value of 167 per percent change in grade, which is plotted in Figure 3-44 (2011 AASHTO, 3-160). The drainage criterion differs from other criteria in that the length of sag vertical curve

determined for it is a maximum, whereas, the length for any other criterion is a minimum. The maximum length of the drainage criteria is greater than the minimum length for other criteria up to 65 mph.

For improved appearance of sag vertical curves, some use was formerly made of a rule-of-thumb for minimum curve length of $100 \cdot A$ or $K = 100$ per percent change in grade. This approximation is a generalized control for small or intermediate values of A . Compared with headlight sight distance, it corresponds to a design speed of approximately 50 miles per hour. On high-type highways, longer curves are appropriate to improve appearance.” (2011 AASHTO, 3-160)

“From the preceding discussion it is evident that design controls for sag vertical curves differ from those for crests, and separate design values are needed. The headlight sight distance appears to be the most logical criterion for general use, and the values determined for stopping sight distances are within the limits recognized in current practice. The use of this criterion to establish design values for a range of lengths of sag vertical curves is recommended. As in the case of crest vertical curves, it is convenient to express the design controls in terms of K for small values of A . This entails some deviation from the computed values of K for small values of A , but the difference is not significant. Exhibit 6 shows the range of computed values and the rounded values of K selected as design controls.

As they were for crest conditions, minimum vertical curve lengths for flat gradients are also recognized for sag conditions. In fact, the same values determined for crest conditions appear to be generally suitable for sag curves as well. Minimum lengths of sag vertical curves are, therefore, equal to three times the design speed in miles per hour.

Sag vertical curves shorter than the lengths computed from Exhibit 6 may be justified for economic reasons in cases where an existing feature, such as a structure not ready for replacement, controls the vertical profile. In certain cases, ramps may also be designed with shorter sag vertical curves. Fixed-source lighting is desirable in such cases. For street design, some engineers accept design of a sag or crest curve where A is about 1 percent or less without a length of calculated vertical curve. However, field modifications during construction usually result in constructing of the equivalent to a vertical curve, even if the curve length is short.” (2011 AASHTO, 3-161)

Design speed (mph)	Stopping sight distance (ft)	Rate of vertical curvature, K*	
		Calculated	Design
15	80	9.4	10
20	115	16.5	17
25	155	25.5	26
30	200	36.4	37
35	250	49.0	49
40	305	63.4	64
45	360	78.1	79
50	425	95.7	96
55	495	114.9	115
60	570	135.7	136
65	645	156.5	157
70	730	180.3	181
75	820	205.6	206
80	910	231.0	231

Exhibit 6 Design Controls for Sag Vertical Curves

(2011 AASHTO Table 3-36, 3-161)

*Rate of vertical curvature, K, is the length of curve (L) per percent algebraic difference on intersecting grades (A), $K = L/A$

Design Controls: Stopping Sight Distance

“To recognize the distinction in design speed and to approximate the range of current practice, minimum lengths of vertical curves are expressed as about three times the design speed in mph, ($L_{min} = 3V$), where V is in miles per hour and L is in feet.

For night driving on highways without lighting, the length of visible roadway is that roadway that is directly illuminated by the headlights of the vehicle. For certain conditions, the minimum stopping sight distance values used for the design exceed the length of visible roadway. First, vehicle headlights have limitations on the distance over which they can project the light intensity levels that are needed for visibility. When headlights are operated on low beams, the reduced candlepower at the source plus the downward projection angle significantly restrict the length of visible roadway surface. Thus, particularly for high-speed conditions, stopping sight distance values exceed road-surface visibility distances afforded by the low-beam headlights regardless of whether the roadway profile is level or curving vertically. Second, for crest vertical curves, the area forward of the headlight beam’s point of tangency with the roadway surface is shadowed and receives only indirect illumination.” (2011 AASHTO, 3-155)

MDOT does not typically adjust for nighttime conditions (headlight restrictions). Vertical curve lengths may be increased on a case by case basis where constraints such as roads, driveways, etc. are present.

“Since the headlight mounting height (typically about 2 feet) is lower than the driver eye height used for design (3.5 feet), the sight distance to an illuminated object is controlled by the height of the vehicle headlights rather than by the direct line of sight. Any object within the shadow zone must be high enough to extend into the headlight beam to be directly illuminated. AASHTO assumes that the bottom of the headlight beam is about 1.3 feet above the roadway at a distance ahead of the vehicle equal to the stopping sight distance. Although the vehicle headlight system does limit roadway visibility, there is some mitigating effect in that other vehicles, whose taillight height typically varies from 1.5 to 2.0 feet, and other sizable objects, receive direct lighting from headlights at stopping sight distance values used for design. Furthermore, drivers are aware that visibility at night is less than during the day, regardless of road and street design features, and they may, therefore, be more attentive and alert. Regardless of these mitigating effects, fixed-source lighting should be considered, where practical, to provide additional mitigation where minimum stopping sight distance cannot be met due to headlight illumination restrictions in sag curves.

There is a near-level section on a crest vertical curve of Type I (see Exhibit 3), but no difficulty with drainage on curbed highways is typically experienced if the vertical curve is sharp enough so that a minimum grade of 0.30 percent is reached at a point about 50 feet from the crest. This corresponds to a K value of 167. Curves flatter than this deserve special attention to ensure proper pavement drainage near the high point of crest vertical curves. It is not intended that a K value of 167 be considered a design maximum. Values larger than this should require a more careful design of the drainage in the area.” (2011 AASHTO, 3-156)

General Control for Vertical Alignment

“In addition to the specific controls for vertical alignment, there are several general controls that should be considered during design.

- A smooth gradeline with gradual changes, as consistent with the type of highways, roads, or streets and the character of terrain, should be sought in preference to a line with numerous breaks and short lengths of grades. Specific design criteria are the maximum grade and the critical length of grade, but the manner in which they are applied and fitted to the terrain on a continuous line determines the suitability and appearance of the finished product.
- The “roller-coaster” or the “hidden-dip” type of profile should be avoided. Such profiles generally occur on relatively straight horizontal alignment where the roadway profile closely follows a rolling natural ground line. Examples of such undesirable profiles are evident on many older roads and streets; they are unpleasant aesthetically and difficult to drive. Hidden dips may create difficulties for drivers who wish to pass because the passing driver may be deceived if the view of the road or street beyond the dip is free of opposing vehicles. Even with shallow dips, this type of profile may be disconcerting because the driver cannot be sure whether or not there is an oncoming vehicle hidden beyond the rise. This type of profile is avoided by the use of horizontal curves or by more gradual grades.
- Undulating gradelines, involving substantial lengths of momentum grades (grades which cause a driver discomfort), should be evaluated for their effect on traffic operation. Such profiles permit heavy trucks to operate at higher overall speeds than is possible when an upgrade is not preceded by a downgrade, but may encourage excessive speeds of trucks with attendant conflicts with other traffic.
- A “broken-back” gradeline (two vertical curves in the same direction separated by a short section of tangent grade) generally should be avoided, particularly in sags where the full view of both vertical curves is not pleasing. This effect is particularly noticeable on divided roadways with open median sections.
- On long grades, it may be preferable to place the steepest grades at the bottom and flatten the grades near the top of the ascent or to break the sustained grade by short intervals of flatter grade instead of providing a uniform sustained grade that is only slightly below the recommended maximum. This is particularly applicable to roads and streets with low design speeds.
- Where at-grade intersections occur on roadway sections with moderate to steep grades, it is desirable to reduce the grade through the intersection. Such profile changes are beneficial for vehicles making turns and serve to reduce the potential of crashes.
- Sag vertical curves should be avoided in cuts unless adequate drainage can be provided.” (2011 AASHTO, 3-163, 3-164)
- Asymmetrical vertical curves should be avoided wherever possible. The equation $K=L/A$ for checking stopping sight distance does not apply on asymmetrical vertical curves. These curves must be checked graphically. (2011 AASHTO, 3-163, 3-164)

PASSING SIGHT DISTANCE

Quick Charts for Passing Sight Distance

Design Speed (mph)	Assumed Speeds (mph)		Passing Sight Distance
	Passed Vehicle	Passing Vehicle	
20	8	20	400
25	13	25	450
30	18	30	500
35	23	35	550
40	28	40	600
45	33	45	700
50	38	50	800
55	43	55	900
60	48	60	1000
65	53	65	1100
70	58	70	1200
75	63	75	1300
80	68	80	1400

Passing Sight Distance for Design of Two-Lane Highways
(2011 AASHTO, Exhibit 3-4, 3-9)

85th- Percentile or Posted or Statutory Speed Limit (mph)	Minimum Passing Sight Distance (ft)
25	450
30	500
35	550
40	600
45	700
50	800
55	900
60	1000
65	1100
70	1200

Minimum Passing Sight Distances for Pavement Marking Criteria
(2011 MMUTCD Table 3B-1, page 352)

PASSING SIGHT DISTANCE (Two-Lane, Two-Way Highways)

“Most roads are two-lane, two-way highways on which vehicles frequently overtake slower moving vehicles. Passing maneuvers in which faster vehicles move ahead of slower vehicles are accomplished on lanes regularly used by opposing traffic. If passing is to be accomplished without interfering with and opposing vehicle, the passing driver should be able to see a sufficient distance ahead, clear of traffic, so the passing driver can decide whether to initiate and to complete the passing maneuver without cutting off the passed vehicle before meeting an opposing vehicle that appears during the maneuver.

When appropriate, the driver can return to the right lane without completing the pass if he or she sees opposing traffic is too close when the maneuver is partially completed. Many passing maneuvers are accomplished without the driver being able to see any potentially conflicting vehicle at the beginning of the maneuver. An alternative to such a design is to provide passing relief lanes.” (2011 AASHTO, 3-8, 3-9)

“Minimum passing sight distances for design of two-lane highways incorporate certain assumptions about driver behavior. Actual driver behavior in passing maneuvers varies widely. To accommodate these variations in driver behavior, the design criteria for passing sight distance should accommodate the behavior of a high percentage of drivers, rather than just the average driver. The following assumptions are made concerning driver behavior in passing maneuvers:

1. The speeds of the passing and opposing vehicles are equal and represent the design speed of the highway.
2. The passed vehicle travels at uniform speed and speed differential between the passing and passed vehicles is 12 mph.
3. The passing vehicle has sufficient acceleration capability to reach the specified speed differential relative to the passed vehicle by the time it reaches the critical position (the point where the passing vehicle is committed to finishing the maneuver or they must abort the maneuver), which generally occurs about 40 percent of the way through the passing maneuver.
4. The lengths of passing and passed vehicles are 19 feet.
5. The passing driver’s perception-reaction time in deciding to abort passing a vehicle is 1 second.
6. If a passing maneuver is aborted, the passing vehicle will use a deceleration rate of 11.2 ft/s^2 , the same deceleration rate used in stopping sight distance criteria.
7. For a completed or aborted pass, the space headway between the passing and passed vehicles is 1 second.
8. The minimum clearance between the passing and opposed vehicles at the point at which the passing vehicle returns to its normal lane is 1 second.

The application of the passing sight distance models using these assumptions is presented in NCHRP Report 605.

The passing sight distance for use in design should be based on a single passenger vehicle passing a single passenger vehicle. While there may be occasions to consider multiple passings, where two or more vehicles are passed, it is not practical to assume such conditions in developing minimum design criteria. Research has shown that longer sight distances are often needed for passing maneuvers when the passed vehicle, the passing vehicle, or both are trucks. Longer sight distances occur in design, and such locations can accommodate an occasional multiple passing maneuver or a passing maneuver involving a truck.” (2011 AASHTO, 3-11, 3-12)

Measurement of Passing Sight Distance

“For all sight distance calculations the height of the driver’s eye is considered to be 3.5 feet above the road surface. The height of the object is considered to be 3.5 feet above the road surface” (2011 AASHTO, 3-14, 3-15)

“The height of most vehicles is 4.25 feet, but the object height is determined to be 3.5 feet due to the height of a vehicle needed to be visible to be recognized as such. “Passing sight distances calculated on this basis are also considered adequate for night conditions because headlight beams of an opposing vehicle generally can be seen from a greater distance than a vehicle can be recognized in the daytime. The choice of object height equal to the driver eye height makes passing sight distance reciprocal (i.e., when the driver of the passing vehicle can see the opposing vehicle, the driver of the opposing vehicle can also see the passing vehicle.” (2011 AASHTO, 3-15)

Design Speed (mph)	Assumed Speeds (mph)		Passing Sight Distance
	Passed Vehicle	Passing Vehicle	
20	8	20	400
25	13	25	450
30	18	30	500
35	23	35	550
40	28	40	600
45	33	45	700
50	38	50	800
55	43	55	900
60	48	60	1000
65	53	65	1100
70	58	70	1200
75	63	75	1300
80	68	80	1400

Exhibit 7 Passing Sight Distance for Design of Two-Lane Highways
(2011 AASHTO, Table 3-4, 3-9)

Passing Sight Distance for Vertical Curves

“Design values of crest vertical curves for passing sight distance differ from those of stopping sight distance because of the different sight distance and object height criteria (3.5 feet is used as the object height as opposed to the 2.0 feet used for stopping sight distance).” (2011 AASHTO, 3-156)

“Generally, it is impractical to design crest vertical curves that provide passing sight distance because of high cost where crest cuts are involved and the difficulty of fitting the resulting long vertical curves to the terrain, particularly for high speed roads. Ordinarily, passing sight distance is provided only at locations where combinations of alignment and profile does not need significant grading. (Exhibit 9) shows computed K values for determining lengths of vertical curves corresponding to passing sight distance values shown in (Exhibit 7).” (2011 AASHTO, 3-157)

Design Speed (mph)	Passing Sight Distance (ft)	Rate of Vertical Curvature, K Design
20	400	57
25	450	72
30	500	89
35	550	108
40	600	129
45	700	175
50	800	229
55	900	289
60	1000	357
65	1100	432
70	1200	514
75	1300	604
80	1400	700

Exhibit 9 Passing Sight Distance for Design of Two-Lane Highways
(2011 AASHTO, Table 3-35, 3-157)

Crest Vertical Curve Equations:

When S is less than L: (2011 AASHTO, Equation 3-45, 3-156)
 $L = (AS^2)/2800$

When S is greater than L:
 $L = 2S - (2800/A)$ (2011 AASHTO, Equation 3-46, 3-156)

Where:

- L = length of crest vertical curve (ft)
- A = algebraic difference in grades (percent)
- S = passing sight distance (ft)

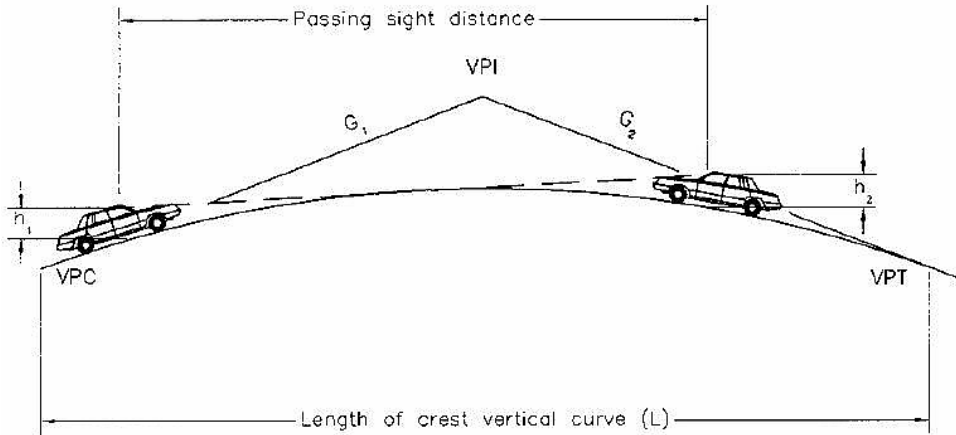

Exhibit 10 Parameters Considered in Determining the Length of a Crest Vertical Curve to Provide Sight Distance (2011 AASHTO, Figure 3-42, 3-152)

Sag Vertical Curve Equations

AASHTO does not have established criteria for the evaluation of passing on a sag vertical curve.

Passing Sight Distance - Pavement Markings

“Minimum passing sight distances for use in design are based on the minimum sight distances presented in the MUTCD as warrants for no passing zones on two lane highways. Design practice should be most effective when it anticipates the traffic controls (i.e., passing and no passing zone markings) that will be placed on highways. Recent research has shown that the MUTCD passing sight distance criteria result in two lane highways that experience very few crashes related to passing maneuvers.” (2011 AASHTO, 3-9)

85th-Percentile or Posted or Statutory Speed Limit (mph)	Minimum Passing Sight Distance (ft)
25	450
30	500
35	550
40	600
45	700
50	800
55	900
60	1000
65	1100
70	1200

Exhibit 11 Minimum Passing Sight Distances for Pavement Marking Criteria (2011 MMUTCD Table 3B-1, page 352)

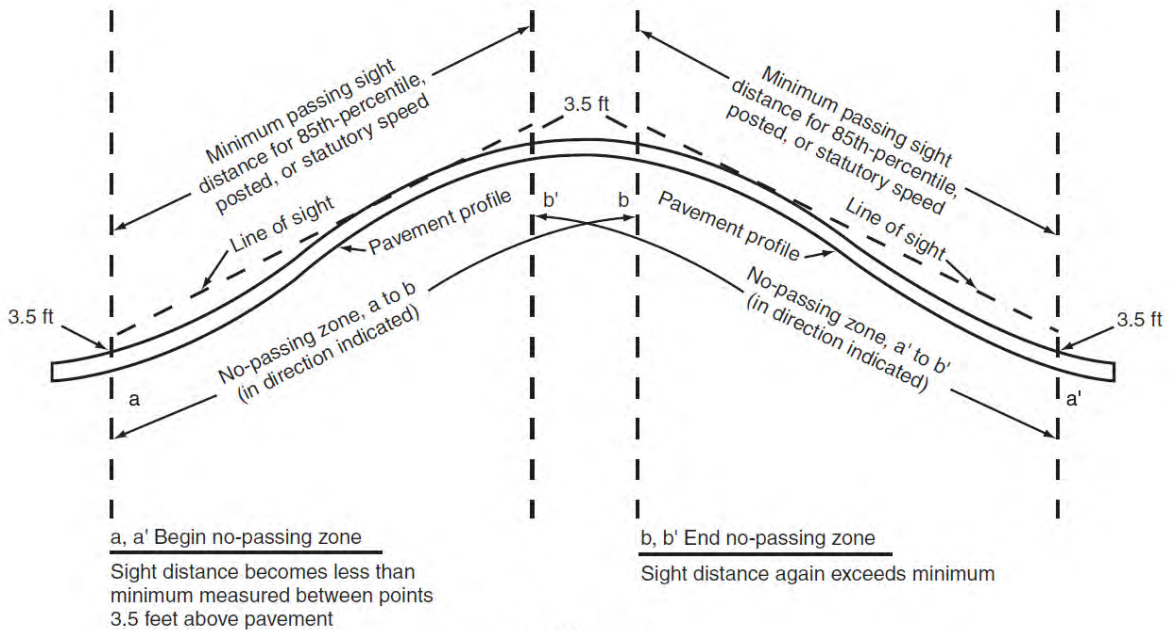

Profile View

Note: No-passing zones in opposite directions may or may not overlap, depending on alignment

Exhibit 12 No-Passing Zone at a Vertical Curve (Pavement Marking)

(2011 MMUTCD, Figure 3B-4 A, page 353)

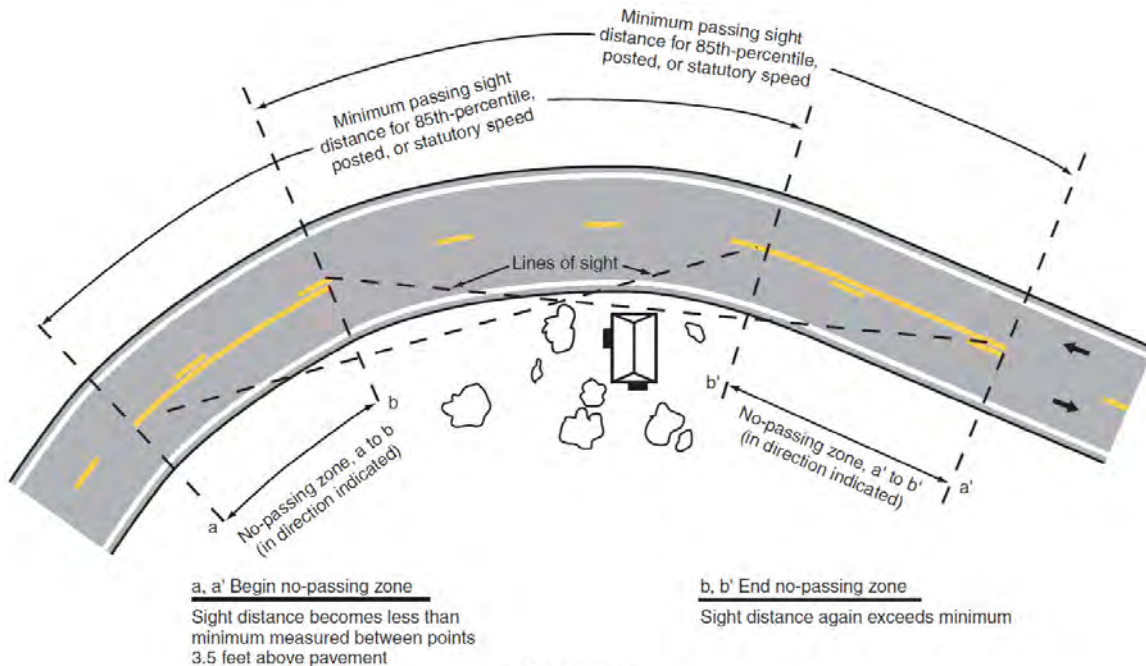

Plan View

Note: No-passing zones in opposite directions may or may not overlap, depending on alignment

Exhibit 13 No-Passing Zone at a Horizontal Curve (Pavement Marking)

(2011 MMUTCD, Figure 3B-4 B, page 353)

See [2011 MMUTCD Part 3](#) for further discussion on pavement marking for passing sight distance where other conditions exist (for example- passing relief lanes, lane drops, etc.).

DECISION SIGHT DISTANCE

Quick Chart for Decision Sight Distance

Design Speed (mph)	Decision Sight Distance (ft)				
	Avoidance Maneuver				
	A	B	C	D	E
30	220	490	450	535	620
35	275	590	525	625	720
40	330	690	600	715	825
45	395	800	675	800	930
50	465	910	750	890	1030
55	535	1030	865	980	1135
60	610	1150	990	1125	1280
65	695	1275	1050	1220	1365
70	780	1410	1105	1275	1445
75	875	1545	1180	1365	1545
80	970	1685	1260	1455	1650

Avoidance Maneuver A: Stop on Rural Road – ($t = 3.0$ sec)

Avoidance Maneuver B: Stop on Urban Road – ($t = 9.1$ sec)

Avoidance Maneuver C: Speed/Path/Direction Change on Rural Road – (t_m varies between 10.2 and 11.2 sec)

Avoidance Maneuver D: Speed/Path/Direction Change on Suburban Road – (t_m varies between 12.1 and 12.9 sec)

Avoidance Maneuver E: Speed/Path/Direction Change on Urban Road – (t_m varies between 14.0 and 14.5 sec)

Decision Sight Distance
(2011 AASHTO, Table 3-3, Page 3-7)

DECISION SIGHT DISTANCE

“Decision sight distance is the distance needed for a driver to detect an unexpected or otherwise difficult-to-perceive information source or condition in a roadway environment that may be visually cluttered, recognize the condition or its potential threat, select an appropriate speed and path, and initiate and complete complex maneuvers.

Because decision sight distance offers drivers additional margin for error and affords them sufficient length to maneuver their vehicles at the same or reduced speed, rather than to just stop, its values are substantially greater than stopping sight distance.

Stopping sight distances are usually sufficient to allow reasonably competent and alert drivers to come to a hurried stop under ordinary circumstances. However, greater distances may be needed where drivers must make complex or instantaneous decisions, where information is difficult to perceive, or when unexpected or unusual maneuvers are needed. Limiting sight distances to those needed for stopping may preclude drivers from performing evasive maneuvers, which often involve less risk and are otherwise preferable to stopping. Even with an appropriate complement of standard traffic control devices in accordance with the *Michigan Manual on Uniform Traffic Control Devices* (MMUTCD), stopping sight distances may not provide sufficient visibility distances for drivers to corroborate advance warning and to perform the appropriate maneuvers. It is evident that there are many locations where it would be prudent to provide longer sight distances. In these circumstances, decision sight distance provides the greater visibility distance that drivers need.” (2011 AASHTO, 3-6)

“Drivers need decision sight distances whenever there is a likelihood for error in either information reception, decision making, or control actions. Examples of critical locations where these kinds of errors are likely to occur, and where it is desirable to provide decision sight distance include interchange and intersection locations where unusual or unexpected maneuvers are needed, changes in cross section such as toll plazas and lane drops, and areas of concentrated demand where there is apt to be “visual noise” from competing sources of information, such as roadway elements, traffic, traffic control devices, and advertising signs. Because of the additional maneuvering space provided, decision sight distances should be considered at critical locations or critical decision points should be moved to locations where sufficient decision sight distance is available.

Decision sight distance criteria that are applicable to most situations have been developed from empirical data. The decision sight distances vary depending on whether the location is on a rural or urban road and on the type of avoidance maneuver needed to negotiate the location properly. Exhibit 14 shows decision sight distance values for various situations rounded for design. As can be seen in the exhibit, shorter distances are generally needed for rural roads and for locations where a stop is the appropriate maneuver. As can also be seen in the exhibit, the values for decision sight distance are substantially longer than those for stopping sight distance. If it is not practical to provide decision sight distance because of horizontal or vertical curvature

or if relocation of decision points is not practical, special attention should be given to the use of suitable traffic control devices for providing advance warning of the conditions that are likely to be encountered.” (2011 AASHTO, 3-7)

Design Speed (mph)	Decision Sight Distance (ft)				
	Avoidance Maneuver				
	A	B	C	D	E
30	220	490	450	535	620
35	275	590	525	625	720
40	330	690	600	715	825
45	395	800	675	800	930
50	465	910	750	890	1030
55	535	1030	865	980	1135
60	610	1150	990	1125	1280
65	695	1275	1050	1220	1365
70	780	1410	1105	1275	1445
75	875	1545	1180	1365	1545
80	970	1685	1260	1455	1650

Avoidance Maneuver A: Stop on Rural Road – ($t = 3.0$ sec)

Avoidance Maneuver B: Stop on Urban Road – ($t = 9.1$ sec)

Avoidance Maneuver C: Speed/Path/Direction Change on Rural Road – (t_m varies between 10.2 and 11.2 sec)

Avoidance Maneuver D: Speed/Path/Direction Change on Suburban Road – (t_m varies between 12.1 and 12.9 sec)

Avoidance Maneuver E: Speed/Path/Direction Change on Urban Road – (t_m varies between 14.0 and 14.5 sec)

Exhibit 14 Decision Sight Distance

(2011 AASHTO, Table 3-3, Page 3-7)

“For the avoidance maneuvers identified in Exhibit 14, the pre-maneuver time is greater than the brake reaction time for stopping sight distance to allow the driver additional time to detect and recognize the roadway or traffic situation, identify alternative maneuvers, and initiate a response at critical locations on the highway. The pre-maneuver component of decision sight distance uses a value ranging between 3.0 and 9.1 seconds.” (2011 AASHTO, 3-8)

“The braking distance for the design speed is added to the pre-maneuver component for avoidance maneuvers A and B as shown in the following equation:”(2011 AASHTO, 3-8)

Decision sight distance for avoidance maneuvers A and B:

$$DSD = 1.47 Vt + 1.075 V^2/a \quad (2011 AASHTO, Equation 3-4, 3-8)$$

Where:

DSD = Decision Sight Distance (ft)

V = Design Speed (mph)

t = Pre-maneuver Time (sec) - [See notes in Exhibit 14]

a = Driver Deceleration (11.2 ft/sec²)

“The braking component is replaced in avoidance maneuvers C, D, and E with a maneuver distance based on maneuver times, between 3.5 and 4.5 seconds, that decrease with increasing speed in accordance with the following equation:”

(2011
AASHTO, 3-8)

Decision sight distance for avoidance maneuvers C, D, and E:

$$DSD = 1.47 V t_m \quad (2011 AASHTO, Equation 3-5, 3-8)$$

Where:

DSD = Decision Sight Distance (ft)

V = Design Speed (mph)

t_m = Total Pre-maneuver and Maneuver Time (sec)- [See notes in Exhibit 14]

INTERSECTION SIGHT DISTANCE

Quick Charts for Intersection Sight Distance

Design Speed (mph)	Stopping Sight Distance (ft)	Intersection Sight Distance for Passenger Cars (ft)	
		Calculated	Design
15	80	165.4	170
20	115	220.5	225
25	155	275.6	280
30	200	330.8	335
35	250	385.9	390
40	305	441.0	445
45	360	496.1	500
50	425	551.3	555
55	495	606.4	610
60	570	661.5	665
65	645	716.6	720
70	730	771.8	775
75	820	826.9	830
80	910	882.0	885

Note: The given intersection sight distance values are for a stopped passenger car to turn left onto a two-lane road with no median and minor road approach grades of 3 percent or less. For other conditions, the sight distance must be recalculated.

Design Intersection Sight Distance – Case B1 – Left-Turn from Stop (2011 AASHTO, Table 9-6, 9-38)

Design Speed (mph)	Stopping Sight Distance (ft)	Intersection Sight Distance for Passenger Cars (ft)	
		Calculated	Design
15	80	143.3	145
20	115	191.1	195
25	155	238.9	240
30	200	286.7	290
35	250	334.4	335
40	305	382.2	385
45	360	430.0	430
50	425	477.8	480
55	495	525.5	530
60	570	573.3	575
65	645	621.1	625
70	730	668.9	670
75	820	716.6	720
80	910	764.4	765

Note: The given intersection sight distances are for a stopped passenger car to turn right onto, or cross, a two-lane road with no median and minor road approach grades of 3 percent or less. For other conditions, the sight distance must be recalculated.

Design Intersection Sight Distance – Case B2 – Right-Turn from Stop and Case B3 – Crossing Maneuver (2011 AASHTO, Table 9-8, 9-41)

INTERSECTION SIGHT DISTANCE

Intersection sight distance is provided at intersections and driveways to allow motorists to perceive the presence of potentially conflicting vehicles. “The driver of a vehicle approaching an intersection should have an unobstructed view of the entire intersection, including any traffic-control devices, and sufficient lengths along the intersecting highway to permit the driver to anticipate and avoid potential collisions. The methods for determining the sight distance needed by drivers either at or approaching intersections are based upon the same principles as stopping sight distance, but incorporate modified assumptions based on observed driver behavior at intersections.” (2011 AASHTO, 9-28)

Intersection sight distance is defined and measured differently for different types of intersection control conditions. Therefore, the sight distance needed at any given intersection is directly related to the type of traffic control present at that intersection, as well as the cross-section and design speed of the major roadway. Because the most prevalent type of intersection traffic control is a stop-control on the minor road approach to an intersection, the focus of the proceeding discussion is on such conditions. For a full discussion regarding intersection sight distance treatments and methodologies for other intersection traffic control conditions, please refer to AASHTO – A Policy on Geometric Design of Highways and Streets, 2011 edition.

Intersections with Stop-Control on the Minor Road

(2011 AASHTO, 9-36)

Intersection sight distance is the sight distance needed to allow the drivers of stopped vehicles to decide when to enter or cross an intersecting roadway. “If the available sight distance for an entering or crossing vehicle is at least equal to the appropriate stopping sight distance for the major roadway, then drivers have sufficient sight distance to anticipate and avoid collisions. However, in some cases, a major-road vehicle may need to stop or slow to accommodate the maneuver by a minor-road vehicle. To enhance traffic operations and safety, intersection sight distances that exceed the stopping sight distances are desirable along the major roadways.” (2011 AASHTO, 9-29)

Intersection sight distance is based, in part, on a gap acceptance methodology. Time gaps have been developed empirically for various conditions based on observed driver behaviors. These time gaps reflect the time gaps in the major road traffic stream typically accepted by vehicles on a minor road approaches. Different time gaps and time gap adjustment factors are utilized for different traffic movements, design vehicles, and physical conditions. It should be noted, the time gaps are independent of the major road design speed; rather, they are a function of the distance the minor road vehicle must travel to execute its intended maneuver (i.e., the number of lanes on the major road).

Intersection sight distance (ISD) equals the major-road design speed, the number of lanes crossed on the major road determined by the distance traveled by the minor-road vehicle during a given time gap. These two components of intersection sight distance are related as shown in the following equation:

$$ISD = 1.47 V t_g \quad (2011 AASHTO, Equation 9-1, 9-37)$$

Where:

ISD = Intersection Sight Distance (ft)

V = Design Speed of Major Road (mph)

t_g = Time Gap for Minor-Road Vehicle to Cross the Major Road (sec)

As previously noted, different time gaps are utilized for different traffic movements and design vehicles. In addition, adjustments to these base time gaps may be required based on the major road cross-section and/or the minor road approach grade. The various time gaps and time gap adjustment factors used to establish design intersection sight distances for different traffic movements and conditions are presented in the following discussions.

Left-Turn from the Minor Road

(2004 AASHTO, Case B1, 9-36 – 9-40)

The time gaps and time gap adjustment factors used to determine the recommended intersection sight distances for left-turns from the minor road are detailed in Exhibit 15. It can usually be assumed the minor road vehicle is a passenger car. However, where substantial volumes of heavy vehicles enter the major road, use of the time gap values for single-unit or combination trucks should be considered.

Design Vehicle	Time Gap (t_g) (seconds) at Design Speed of Major Road
Passenger Car	7.5
Single-Unit Truck	9.5
Combination Truck	11.5
Note: Time gaps shown are for a stopped vehicle to turn left onto a two-lane road with no median and approach grades of 3 percent or less. The table values require adjustment as follows:	
<i>For Two-Way Roadways with More than Two Lanes:</i> Add 0.5 seconds for passenger cars or 0.7 seconds for trucks for each additional lane, from the left, in excess of one, to be crossed by the left-turning vehicle.	
<i>For Minor Road Approach Grades:</i> If the rear wheels of the design vehicle are located on an upgrade which exceeds 3 percent, Add 0.2 seconds for each percent of grade.	

Exhibit 15 Time Gap for Case B1 – Left-Turn from Stop

(2011 AASHTO, Table 9-5, 9-37)

“For example, a passenger car turning left onto a two-lane major road should be provided intersection sight distance equivalent to a time gap of 7.5 seconds in the major road traffic stream. If the design speed of the major road is 60 mph, this corresponds to a sight distance of $1.47 (60) (7.5) = 661.5$, or 665 feet rounded for design.

A passenger car turning left onto an undivided three-lane or four-lane roadway will need to cross two near lanes, rather than just one. This increases the recommended time gap in the major road traffic stream from 7.5 seconds to 8.0 seconds. The corresponding value of sight distance for this example would be 706 feet. If the minor road approach to such an intersection is located on a 4 percent upgrade, then the time gap selected for intersection sight distance should be further increased from 8.0 seconds to 8.8 seconds, equivalent to an increase of 0.2 seconds for each percent of grade.” (2011 AASHTO, 9-37)

For convenience, the base time gaps (unadjusted for minor road approach grades) for various design vehicles and major-road cross-sections are tabulated in Exhibit 16.

Design Vehicle	Time Gap (seconds) needed for Major Road CrossSection Consisting of:					
	2-Lanes	3-Lanes	4-Lanes	5-Lanes	6-Lanes	7-Lanes
Passenger Car	7.5	8.0	8.0	8.5	8.5	9.0
Single-Unit Truck	9.5	10.2	10.2	10.9	10.9	11.6
Combination Truck	11.5	12.2	12.2	12.9	12.9	13.6
Note: Time gaps are for a stopped vehicle to turn left onto a major road with no median storage and minor road approach grades of 3 percent or less. For minor road approach grades in excess of 3 percent, add 0.2 seconds to the time gap for each percent of grade.						

Exhibit 16 Time Gap for Case B1 – Left-Turn from Stop
(2011 AASHTO, Expanded Table 9-5, 9-37)

Again, for convenience, the recommended intersection sight distance values for left-turns under the most prevalent conditions (stopped passenger car turning onto a two-lane road with minor road approach grades of 3 percent or less) are provided in Exhibit 17.

Design Speed (mph)	Stopping Sight Distance (ft)	Intersection Sight Distance for Passenger Cars (ft)	
		Calculated	Design
15	80	165.4	170
20	115	220.5	225
25	155	275.6	280
30	200	330.8	335
35	250	385.9	390
40	305	441.0	445
45	360	496.1	500
50	425	551.3	555
55	495	606.4	610
60	570	661.5	665
65	645	716.6	720
70	730	771.8	775
75	820	826.9	830
80	910	882.0	885

Exhibit 17 Design Intersection Sight Distance Case B1 – Left-Turn from Stop
(2011 AASHTO, Table 9-6, 9-38)

Right-Turn from the Minor Road

(2011 AASHTO, Case B2, 9-40 – 9-42)

And

Crossing Maneuver from the Minor Road

(2011 AASHTO, Case B3, 9-43)

The time gaps and time gap adjustment factors used to determine the design intersection sight distances for right-turns and crossing maneuvers from the minor road are detailed in Exhibit 18. It can usually be assumed the minor road vehicle is a passenger car. However, where substantial volumes of heavy vehicles enter the major road, use of the time gap values for single-unit or combination trucks should be considered.

Design Vehicle	Time Gap (t_g) (seconds) at Design Speed of Major Road
Passenger Car	6.5
Single-Unit Truck	8.5
Combination Truck	10.5
Note: Time gaps shown are for a stopped vehicle to turn right onto or cross a two-lane road with no median and approach grades of 3 percent or less. The table values require adjustment as follows:	
<i>For Roadways with More than Two Lanes:</i> For crossing a major road with more than two lanes, add 0.5 seconds for passenger cars or 0.7 seconds for trucks for each additional lane to be crossed, and for narrow medians that cannot store the design vehicle.	
<i>For Minor Road Approach Grades:</i> If the rear wheels of the design vehicle are located on an upgrade which exceeds 3 percent, add 0.1 seconds for each percent of grade.	

Exhibit 18 Time Gap for Case B2 – Right-Turn from Stop and Case B3 – Crossing Maneuver (2011 AASHTO, Table 9-7, 9-40)

As an example, a passenger car crossing a two-lane major road should be provided intersection sight distance equivalent to a time gap of 6.5 seconds in the major road traffic stream. If the design speed of the major road is 60 mph, this corresponds to a sight distance of $1.47(60)(6.5) = 573.3$, or 575 feet rounded for design.

Another example, a passenger car crossing an undivided five-lane roadway will need to cross three additional lanes beyond the first two. This increases the recommended time gap in the major road traffic stream from 6.5 seconds to 8.0 seconds, equivalent to an increase of 0.5 seconds for each additional lane in excess of two. The corresponding value of sight distance in this example would be 706 feet. If the minor road approach to such an intersection is located on a 5 percent upgrade, then the time gap should be further increased from 8.0 seconds to 8.5 seconds, equivalent to an increase of 0.1 seconds for each percent of grade.

For convenience, the base time gaps (unadjusted for minor road approach grades) for various design vehicles and major-road cross-sections are tabulated in Exhibit 19.

Design Vehicle	Time Gap (seconds) needed for Major Road Cross Section Consisting of:					
	2-Lanes	3-Lanes	4-Lanes	5-Lanes	6-Lanes	7-Lanes
Passenger Car	6.5	7.0	7.5	8.0	8.5	9.0
Single-Unit Truck	8.5	9.2	9.9	10.6	11.3	12.0
Combination Truck	10.5	11.2	11.9	12.6	13.3	14.0

Note: Time gaps are for a stopped vehicle to cross a major road with no median storage and minor road approach grades of 3 percent or less. For minor road approach grades in excess of 3 percent, add 0.1 seconds to the time gap for each percent of grade.

Exhibit 19 Time Gap for Case B2 – Right-Turn from Stop and Case B3 – Crossing Maneuver (2011 AASHTO, Expanded from Table 9-7, 9-40)

Again, for convenience, the recommended intersection sight distance values for right-turns and crossing maneuvers under the most prevalent conditions (stopped passenger car turning right onto or crossing a two-lane road with minor road approach grades of 3 percent or less) are provided in Exhibit 20.

Design Speed (mph)	Stopping Sight Distance (ft)	Intersection Sight Distance for Passenger Cars (ft)	
		Calculated	Design
15	80	143.3	145
20	115	191.1	195
25	155	238.9	240
30	200	286.7	290
35	250	334.4	335
40	305	382.2	385
45	360	430.0	430
50	425	477.8	480
55	495	525.5	530
60	570	573.3	575
65	645	621.1	625
70	730	668.9	670
75	820	716.6	720
80	910	764.4	765

Note: The given intersection sight distances are for a stopped passenger car to turn right onto, or cross, a two-lane road with no median and minor road approach grades of 3 percent or less. For other conditions, the sight distance must be recalculated.

Exhibit 20 Design Intersection Sight Distance – Case B2 – Right-Turn from Stop and Case B3 – Crossing Maneuver (2011 AASHTO, Table 9-8, 9-41)

Intersection sight distance design for left-turns at divided highways should consider the median width. If the median is wide enough to store the selected design vehicle with clearance to the through lanes of approximately 3 feet at both ends of the vehicle, then each direction of the divided roadway may be treated as a separate intersection. If, however, the median is not wide enough to adequately store the design vehicle, then the intersection should be treated as a single entity, and the various sight distances should be provided at the initial minor road approach to the intersection. In such cases, the median width should be converted to an equivalent number of lanes. For example, a median width of 24 feet would be equivalent to two additional lanes when applying adjustments to the base time gaps for left-turns and crossing maneuvers.

No adjustment of the recommended intersection sight distance value is generally needed for the major road grade because both the major road vehicle and the minor road vehicle will be on the same grade when departing the intersection. However, if the minor road design vehicle is a heavy truck and the intersection is located near a sag vertical curve with grades over 3 percent, then an adjustment to extend the recommended sight distance based on the major road grade should be considered. (2011 AASHTO, 9-38)

Intersection Sight Distance Considerations for Signalized Intersections

Intersections controlled by traffic signals are thought by some not to require the provision of intersection sight distance. It is reasoned that, because conflicting traffic movements are not permitted to occur simultaneously, full intersection sight distance is not needed. However, due to a variety of operational possibilities, intersection sight distance should be available for the following reasons: traffic signal malfunctions, signal violations by motorists, flasher mode of signal operation, and/or permitted right-turns-on-red. It should be noted that traffic signals are a viable, cost-effective treatment for intersections with limited intersection sight distance. However, at such locations, the traffic signal should not be operated in flasher mode, and right-turns-on-red should be prohibited.

Determination and Measurement of Intersection Sight Distance

In calculating and measuring intersection sight distance, it is necessary to specify the positions of both the observer's (driver's) eye and of the object vehicle. This includes the elevation or height above the roadway of both the driver's eye and the object vehicle, and the lateral placement of each along the intersecting roadway approaches. Thus, the intersection sight distance available at any given location is dependent on both the horizontal and vertical alignment of the intersecting roads. This fact should be kept in mind when designing the profiles of intersecting roadways, especially if the intersection is located on a superelevated section of the major road.

The position of the driver's eye is assumed to be in the center of the appropriate minor road approach lane, 18.0 feet from the edge of the outside through lane of the major road. This represents the typical position of the minor-road driver's eye when a vehicle is stopped at the intersection. The value of 18.0 feet is derived by providing for an off- set of 10 feet from the edge of the major road's outside through lane to the front of the stopped vehicle, and an additional 8.0 feet from the front of the stopped vehicle to the driver's eye (measurements of the current U.S. passenger car fleet indicate the distance from the front of the vehicle to the driver's eye is almost always 8.0 feet or less). Field observations of vehicle stopping positions found, where sight distance is restricted, drivers will stop with the front of their vehicles 6.5 feet or less from the edge of the major road's traveled way. Therefore, where intersection sight distance is constrained, the driver's eye position may be assumed to be 14.5 feet from the edge of the major road outside through lane. Where the intersection sight distance is based upon a passenger car as the design vehicle, the driver's eye height is assumed to be 3.5 feet above the surface of the roadway. Where the intersection sight distance is based upon a single- unit or combination truck as the design vehicle, a driver's eye height of 7.6 feet may be assumed. (2011 AASHTO, 3-14)

The position of the object vehicle is assumed to be at the center of the nearest oncoming through lane from each direction along the approach legs of the major roadway, at a distance equal to the recommended intersection sight distance.

Intersection sight distance is measured to both the left and right, to account for traffic approaching from either direction. The object height is assumed to be 3.5 feet above the surface of the roadway. "This object height is based on a vehicle height of 4.35 feet, which represents the 15th percentile of vehicle heights in the current passenger car fleet, less an allowance of 10 inches. This allowance represents a near-maximum value for the portion of a passenger car that needs to be visible for another driver to recognize it as the object. The use of an object height equal to the driver eye height makes intersection sight distances reciprocal (i.e., if one driver can see another vehicle, then the driver of that vehicle can also see the first vehicle)." (2011 AASHTO, 9-31)

The positions of the driver's eye and of the object vehicle establish two vertices of a triangle known as a clear sight triangle. The third vertex is located at the intersection of the two lines which pass through the driver's eye position and the object position along the respective approach legs of the intersection. Each minor road approach to a two-way major roadway has two clear sight triangles, one to the left, and one to the right. Such clear sight triangles are illustrated in Figure 1 at the end of this section. (2011 AASHTO, Figure 9-15, 9-30)

Clear sight triangles provide the sight distance necessary for a vehicle stopped on a minor road approach to an intersection to either enter or cross the major roadway. The provision of clear sight triangles also allows the drivers of vehicles on the major road to see any vehicles stopped on the minor road approach, and to be prepared to slow or stop, if necessary. Therefore, clear sight triangles should be kept free of

any objects that may obstruct a driver's view of potentially conflicting vehicles. Such objects may include parked vehicles, buildings, highway structures, roadside hardware, trees, bushes, unmowed grass, tall crops, hedges, walls, fences, and even the terrain itself. Particular attention should be given to the evaluation of clear sight triangles at interchange ramp/crossroad intersections where features such as bridge railings, guardrail, piers, and/or abutments may present potential sight obstructions. Extra precaution should also be taken at intersections located on superelevated sections of the major road, where the terrain itself can potentially restrict the available intersection sight distance.

Field Measurement of Intersection Sight Distance

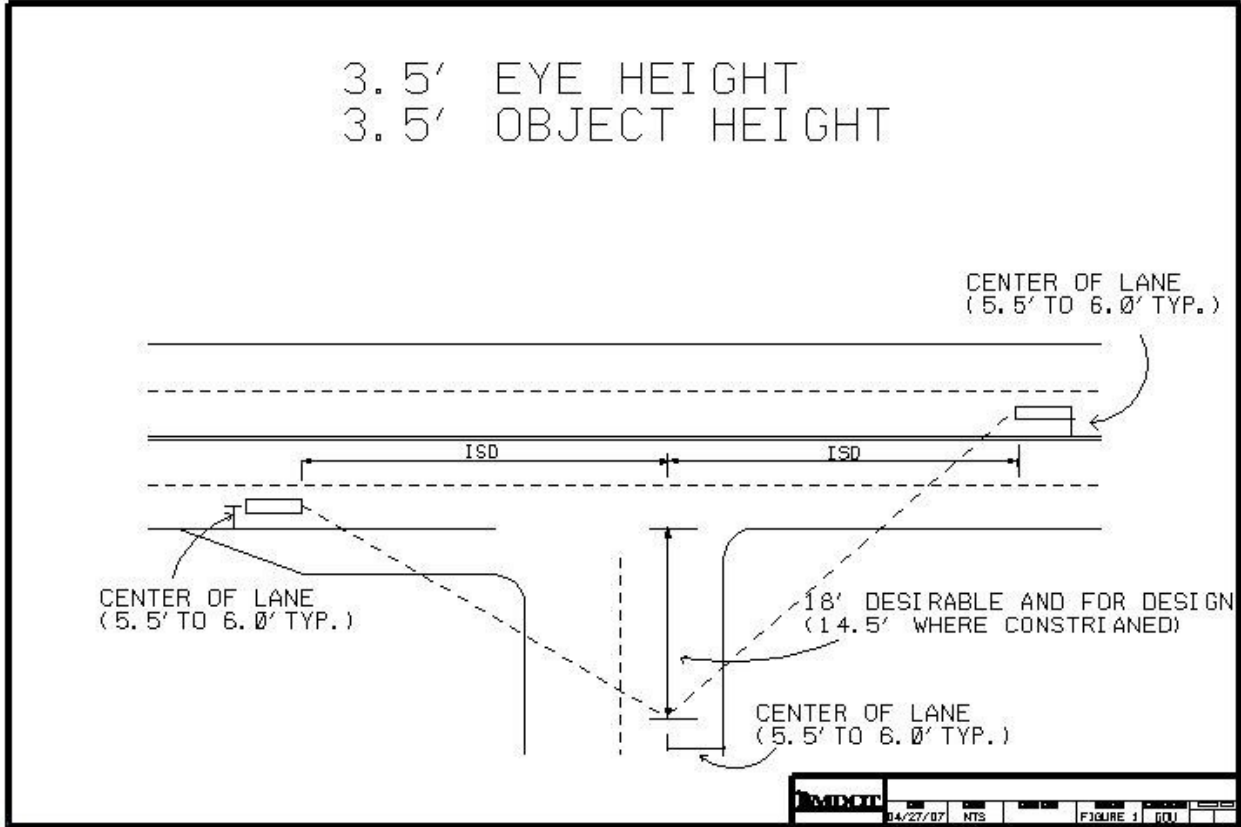

Figure 1 Measurement of Intersection Sight Distance

At minimum, a two-person crew is required. A three-person crew is recommended for additional safety (the third person acting as an extra traffic observer).

Equipment Needed

- Hard hats, safety vests, safety shoes, and any other safety equipment required by the Michigan Department of Transportation.
- Flashlight.
- Measuring wheel.
- Chalk or lumber crayons.
- A 1 inch x 4 inch sighting board with a small hole (3/16 inch diameter) drilled in the center at a height of 3.5 feet. (See Figure 2)
- A 1 inch X 4 inch target board with two holes drilled into it with circumferences large enough to accommodate a flashlight handle. One hole should be drilled at a height of 3.5 feet; the other hole should be drilled at a height of 2.0 feet. (See Figure 2)
- Two-way communication system.

Procedure

Two points are marked with chalk or lumber crayon in the center of the appropriate minor road approach lane, 18.0 feet and 14.5 feet from the edge of the major road through lane. These two points represent the desirable position and the constrained position for the driver's eye when a vehicle is stopped, waiting to enter or cross the intersecting roadway. From each of the two marked points, a crew member looks through the hole in the sighting board to the other crew member. The second crew member holds the target board in the center of the nearest oncoming through lane from each direction along the approach legs of the major roadway, with the flashlight in the hole at a height of 3.5 feet. The person with the sighting board radios or motions for the person with the target board to either walk backward or forward until the flashlight is just visible due to tall grass, horizontal or vertical curvature of the roadway, guardrail, or any other sight obstructions. The person holding the target board then marks that spot with the chalk or lumber crayon, and using the measuring wheel, measures the distance along the major roadway between the two crew members. This is done to the left and to the right, to account for each approach direction of major-road traffic. The resulting distances are the available intersection sight distances, as measured from the 18.0 feet and 14.5 feet points on the minor-road approach to the intersection. (See Figure 1)

Note: The hole in the target board at the 2.0 foot height can be used to measure the available stopping sight distances along roadways.

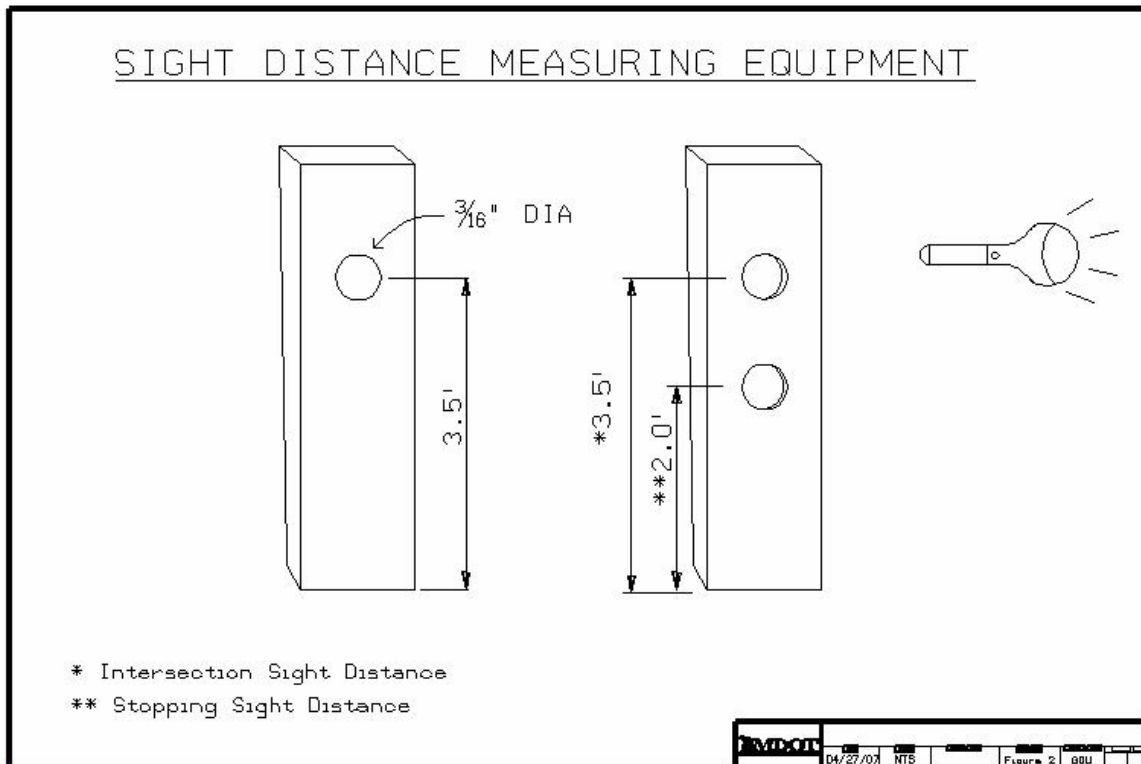

Figure 2 Measurement Equipment for Sight Distance

REFERENCES

1. American Association of State Highway and Transportation Officials. 2011. *A Policy on Geometric Design of Highways and Streets*. 6th ed. Washington D.C.: American Association of State Highway and Transportation Officials. Used by permission.
2. Michigan Department of Transportation. 2011. *Michigan Manual on Uniform Traffic Control Devices for Streets and Highways*. Lansing: Michigan Department of Transportation.